

# Gradient

1. Below are shown a series of ramps. Find the gradient of each ramp.

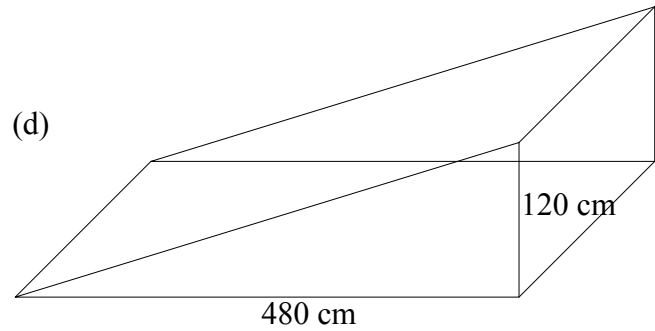

2. Below are shown pictures of escalators. Calculate the gradient of each escalator.

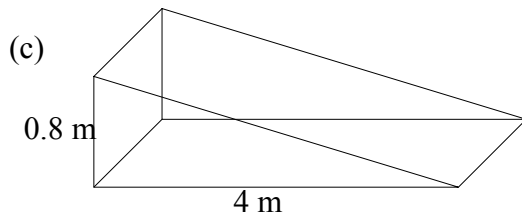
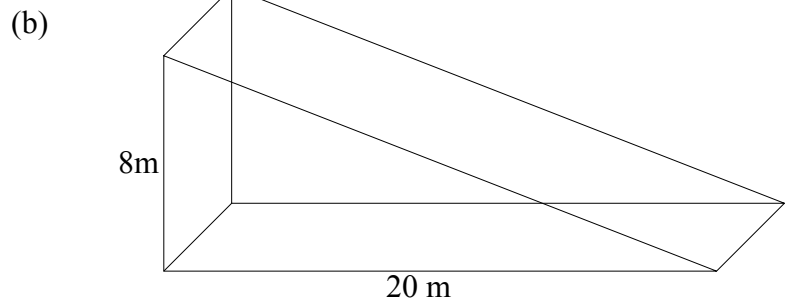
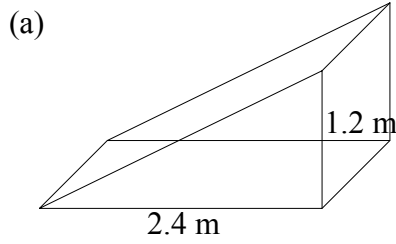
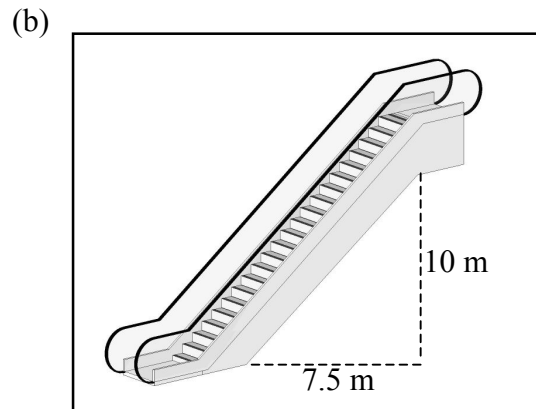
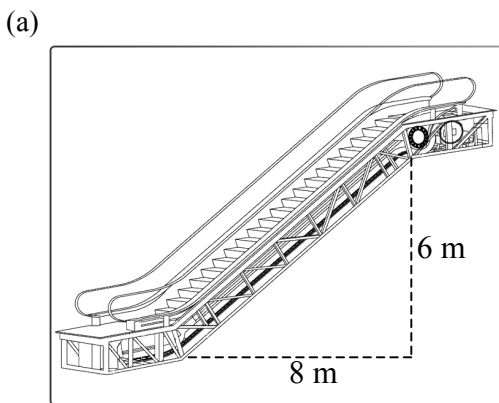

3.

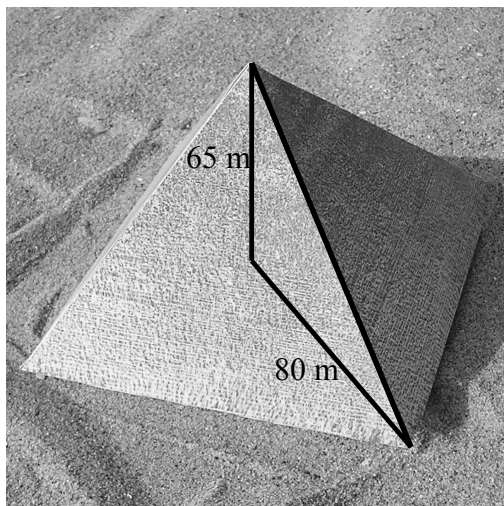

Calculate the gradient of the sloping edge of this pyramid.

4. The diagrams below show the take-off path of aeroplanes. Calculate the gradient of each path.

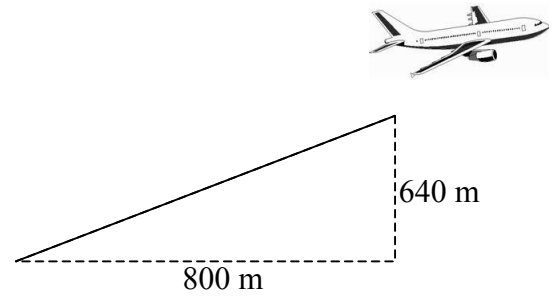
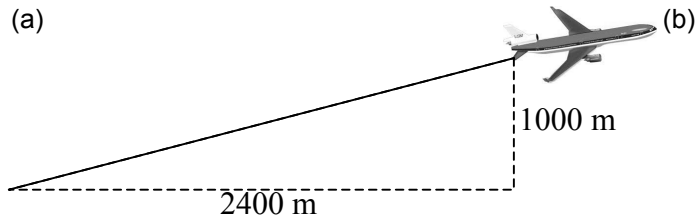

5. The end view of the roof of a house is shown opposite. Calculate the gradient of the sloping edge of the roof.

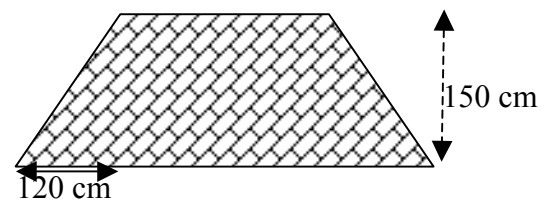

6. The diagram shows a section of a rollercoaster. Find the gradient of this section of the rollercoaster.

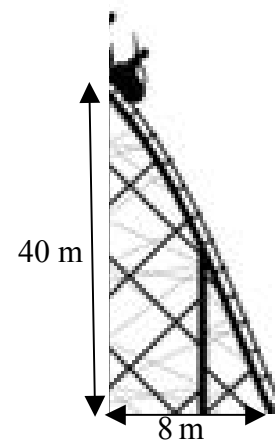

7. The diagram shows a man running on a road up a hill. Calculate the gradient of the road.

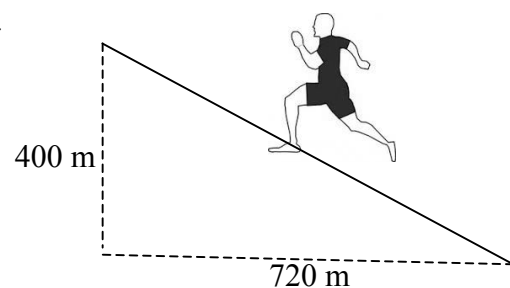

8. The diagram shows a ladder resting against a wall. If the ladder has a gradient greater than 5.5 it is unsafe. Is the ladder shown opposite unsafe?

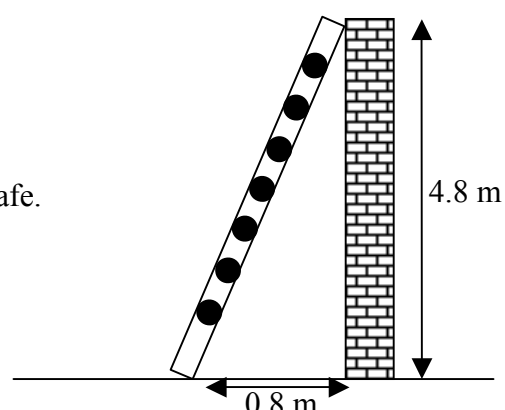

9. A fire engine is positioned outside a block of flats.  
Calculate the gradient of the fire engine's ladder.

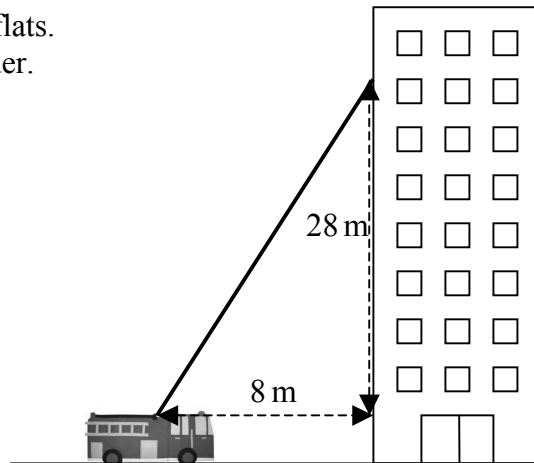

10. The diagram shows a skier about to descend a steep slope.  
Calculate the gradient of this slope.

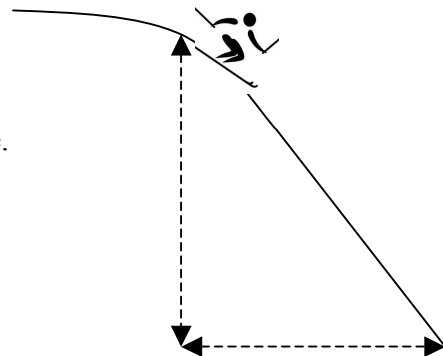

11. Plot each pair of points on a graph and find the gradient of the line joining each pair.

- |                         |                          |                           |
|-------------------------|--------------------------|---------------------------|
| (a) A(2,3) and B(5,9)   | (b) C(-1,-1) and D(-9,3) | (c) E(-4,-2) and F(-9,-9) |
| (d) G(2,-1) and H(8,-3) | (e) I(2,1) and J(10,5)   | (f) K(-2,-8) and L(1,10)  |

12. (a) Plot the points P(-8,2), Q(-5,-3) and R(2,2).  
(b) Find a point S such that PQRS is a kite.  
(c) Find the gradient of each side of the kite.

13. (a) Plot the points U(1,3), V(7,6) and W(5,10).  
(b) Find the point X such that UVWX is a rectangle.  
(c) Find the gradient of each side of the rectangle.  
(d) What do you notice about your answers?

14. (a) Plot the points G(1,2), H(4,-2) and K(8,1).

- (b) Find a point  $L$  such that  $GHL$  is a square.
- (c) Find the gradient of each side of your square.
- (d) What do you notice about your answers?